

BLMFS5 Series

Linear Motors

Steel-core forcer coil provides high force per unit volume

Continuous force to 697.1 N (156.7 lb); peak force to 1507.2 N (338.8 lb)

Unlimited travel length by stacking magnet tracks

High-energy, rare-earth magnets used in magnet track for high acceleration capability

Optional water cooling for highest throughput

Ideal for pick and place, assembly, and general automation

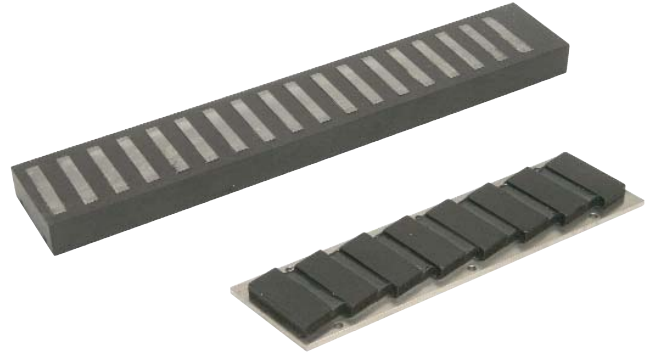

The BLMFS5 series linear motors are designed to provide a higher throughput and lower profile alternative to conventional linear motor applications. This is achieved through a proprietary manufacturing process and laminated iron-core design.

The moving forcer coil assembly contains Hall-effect devices and a thermal sensor, and is a compact, reinforced ceramic epoxy structure.

The BLMFS5 series utilizes steel laminations to produce more force for a given forcer coil length. This makes it ideal for high speed point-to-point motion. The attraction force can also be used as a bearing pre-load.

Offering high peak forces in its standard configuration, BLMFS5 motors are available with higher-power magnets that can be used to increase output force.

These linear motors are ideal for any application requiring high levels of positioning resolution and accuracy. Tracks are stackable for any travel length. The BLMFS5 linear motors are also ideal for clean-room use as they produce no particulates.

The BLMFS5 can be driven using standard Aerotech brushless amplifiers and controllers to provide a complete, integrated system.

BLMFS5 Series SPECIFICATIONS

Motor Model	Units	BLMFS5-142		BLMFS5-262		BLMFS5-382	
Performance Specifications^(1,5)							
Continuous Force, Water Cooling ^(2,6)	N (lb)	323.4 (72.7)		522.3 (117.4)		697.1 (156.7)	
Continuous Force, No Cooling ⁽²⁾	N (lb)	174.8 (39.3)		282.3 (63.5)		376.8 (84.7)	
Peak Force ⁽³⁾	N (lb)	699.3 (157.2)		1129.2 (253.9)		1507.2 (338.8)	
Cogging Force	N (lb)	57.8 (13.0)		62.3 (14.0)		67.2 (15.1)	
Attractive Force	N (lb)	2410 (542)		4446 (1000)		6482 (1457)	
Electrical Specifications⁽⁵⁾							
Winding Designation		-A	-B	-A	-B	-A	-B
BEMF (Line-Line, Max)	V/m/s (V/in/s)	21.99 (0.56)	43.97 (1.12)	21.99 (0.56)	43.97 (1.12)	21.99 (0.56)	43.97 (1.12)
Continuous Current, Water Cooling ^(2,6)	Amp _{pk} (Amp _{rms})	16.91 (11.96)	8.45 (5.98)	27.31 (19.31)	13.65 (9.65)	36.45 (25.77)	18.22 (12.89)
Continuous Current, No Cooling ⁽²⁾	Amp _{pk} (Amp _{rms})	9.14 (6.46)	4.57 (3.23)	14.76 (10.44)	7.38 (5.22)	19.70 (13.93)	9.85 (6.97)
Peak Current, Stall ⁽²⁾	Amp _{pk} (Amp _{rms})	36.56 (25.85)	18.28 (12.93)	59.04 (41.75)	29.52 (20.87)	78.80 (55.72)	39.40 (27.86)
Average Force Constant, Sine Drive ^(4,8)	N/Amp _{pk} (lb/Amp _{pk})	19.13 (4.30)	38.25 (8.60)	19.13 (4.30)	38.25 (8.60)	19.13 (4.30)	38.25 (8.60)
	N/Amp _{rms} (lb/Amp _{rms})	27.05 (6.08)	54.10 (12.16)	27.05 (6.08)	54.10 (12.16)	27.05 (6.08)	54.10 (12.16)
Motor Constant ^(2,4)	N/√W (lb/√W)	14.40 (3.24)	14.40 (3.24)	20.37 (4.58)	20.37 (4.58)	24.94 (5.61)	24.94 (5.61)
Resistance, 25°C (Line-Line)	ohms	1.7	6.7	0.8	3.4	0.6	2.2
Inductance (Line-Line)	mH	9.90	39.60	4.95	19.80	3.30	13.20
Thermal Resistance, Water Cooling ⁽⁶⁾	°C/W	0.20		0.15		0.13	
Thermal Resistance, No Cooling	°C/W	0.68		0.52		0.44	
Maximum Bus Voltage	VDC	340	340	340	340	340	340
Mechanical Specifications							
Coil Weight	kg (lb)	1.42 (3.12)		2.31 (5.08)		3.81 (8.38)	
Coil Length	mm (in)	142.0 (5.59)		262.0 (10.31)		382.0 (15.04)	
Heat Sink	mm (in)	380x380x13 (15x15x0.5)					
Magnet Track Weight	kg/m (lb/ft)	4.40 (2.95)					
Magnetic Pole Pitch	mm (in)	30.00 (1.18)					

Notes:

- Performance is dependent upon heat sink configuration, system cooling conditions, and ambient temperature.
- Values shown @ 100°C rise above a 25°C ambient temperature, with motor mounted to the specified aluminum heat sink.
- Peak force assumes correct rms current; consult Aerotech.
- Force constant and motor constant specified at stall.
- All performance and electrical specifications ±10%.
- Maximum winding temperature is 125°C.
- Ambient operating temperature range 0°C - 25°C. Consult Aerotech for performance in elevated ambient temperatures.
- All Aerotech amplifiers are rated A_{pk}; use torque constant in N-m/A_{pk} when sizing.

BLMFS5 Series DIMENSIONS

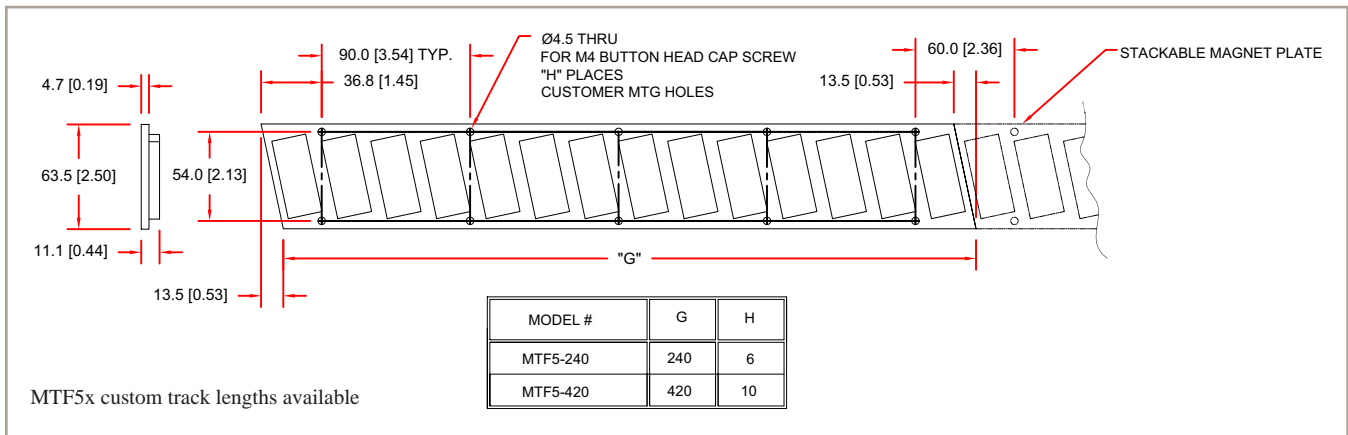
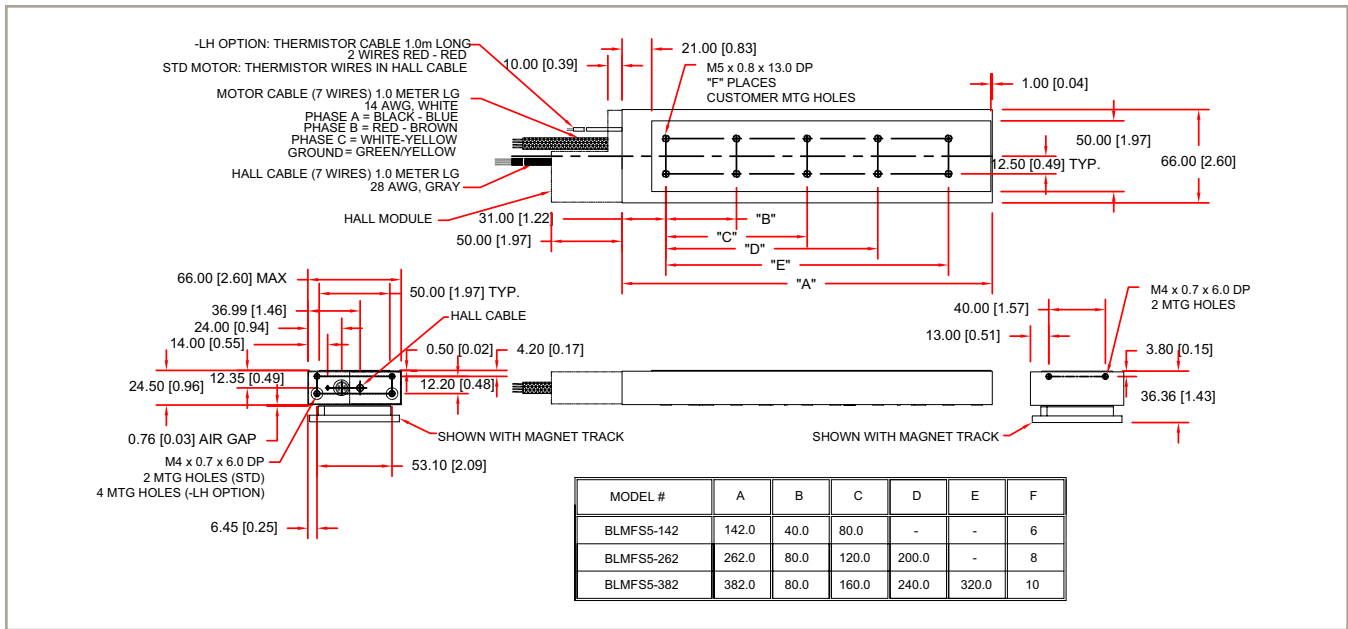

BLMFS5 Series ORDERING INFORMATION

Ordering Example

BLMFS5	-142	-A
Motor Series	Forcer Coil Length	Standard Winding
BLMFS5	142 mm, 262 mm, 382 mm	76 cm (2.5 ft) flying leads std

Brushless Linear Servomotors - BLMFS5 Series Flat Steel Lamination Forcer Coils

BLMFS5-142-A	Flat linear motor coil, steel lamination design for higher force with HED and temperature switch
BLMFS5-262-A	Flat linear motor coil, steel lamination design for higher force with HED and temperature switch
BLMFS5-382-A	Flat linear motor coil, steel lamination design for higher force with HED and temperature switch

BLMFS Options

-LH	Remove HED sensor from BLMFS series forcer coil
-B	Optional winding
-V	Vacuum prepared

Note: Water cooling available — consult factory.

Flat Magnet Tracks – MTF Series for BLMF motors

MTF5-240	Flat magnet track, for use with BLMFS5 forcer coil, 240 mm (9.4 in) length
MTF5-420	Flat magnet track, for use with BLMFS5 forcer coil, 420 mm (16.5 in) length
MTF5x	Custom flat magnet track length available. Please consult factory.