

BM Series

Brushless Rotary Servomotors

Standard NEMA frame sizes

Neodymium iron boron rare-earth magnets maximize performance

Skewed stator with multi-pole design minimizes torque ripple and cogging for smooth velocity control over a greater speed range

Optional IP65-level construction allows use in harsh environments

Choice of encoder/Hall output or resolver feedback

Optional brake, front shaft seal, and precision gear reducers



17, 23, 34, 42, and IEC 142. This makes it easy to mount any motor to Aerotech's gearbox line with no adapter plates. These motors are well-suited to general purpose and high-end servo applications.

High-Performance Design

The BM series consists of Aerotech's high-performance brushless rotary servomotors. The motors feature neodymium iron boron magnets for maximum torque and acceleration in a small package. A skewed stator design and an eight-pole rotor provide low torque ripple and smooth velocity. The BM series motors can reach speeds up to 10,000 rpm and accelerations to 270,000 rad/sec² for improved machine cycle times. Unlike DC brush-type servomotors, the BM series are brushless and maintenance free. This makes them ideal for critical applications where downtime cannot be tolerated.

In addition, the BM series motors have very high power density resulting in high torque in a compact package. Optional IP65 sealing make these motors ideal for harsh environments such as machine tool.

Wide Torque Range

The BM motor series covers a wide range of torque and package sizes. Continuous output torque ranges from 0.14 N-m (20.0 oz-in) to 31.6 N-m (280 lb-in), with peak torques to 94.9 N-m (840 lb-in). Standard frame sizes include NEMA

Application Flexibility

The standard motor has a 1000-line encoder (4000-line count after quadrature), RS-422 line driver output with Hall effect device outputs for commutation, and MS connectors. Options include increased encoder resolution, resolver feedback, sealing for IP65 level protection, brakes, and gearboxes. Standard models can be delivered from stock and custom variations can be engineered to your requirements with minimal lead time.



All Aerotech motors are manufactured following ISO9001 standards.

BM Series SPECIFICATIONS

Model		BM20	BM75	BM130	BM200
Performance Specifications^(1,5)					
Stall Torque, Continuous ^(2,8)	N-m	0.14	0.55	1.00	1.20
	oz-in	20.0	78.3	141.5	170.0
Peak Torque ⁽³⁾	N-m	0.7	1.4	2.5	3.0
	oz-in	100	196	354	425
Rated Speed	rpm	4,000	4,000	4,000	4,000
Rated Power Output, Continuous	watts	59	232	419	503
Electrical Specifications⁽⁵⁾					
BEMF Constant (line to line, max)	Volts _{pk} /krpm	5.4	6.7	16.0	14.5
Continuous Current, Stall ^(2,8)	Amp _{pk}	2.8	10.0	7.5	10.0
	Amp _{rms}	2.0	7.1	5.3	7.1
Peak Current, Stall ⁽³⁾	Amp _{pk}	13.8	25.0	18.9	25.0
	Amp _{rms}	9.8	17.7	13.3	17.7
Torque Constant ^(4,9)	N-m /Amp _{pk}	0.05	0.06	0.13	0.12
	oz-in /Amp _{pk}	7.2	7.8	18.8	17.0
	N-m /Amp _{rms}	0.07	0.08	0.19	0.17
	oz-in /Amp _{rms}	10.2	11.1	26.5	24.0
Motor Constant ^(2,4)	N-m/√W	0.028	0.052	0.088	0.107
	oz-in/√W	4.02	7.33	12.43	15.18
Resistance, 25°C (line to line)	ohms	2.8	1.0	2.0	1.1
Inductance (line to line)	mH	1.74	0.80	1.80	1.10
Maximum Bus Voltage	VDC	80	340	340	340
Thermal Resistance	C/W	5.27	1.14	1.00	1.04
Number of Poles	P	2	8	8	8
Mechanical Specifications					
Motor Weight	kg	0.5	1.1	1.5	2.0
	lb	1.00	2.42	3.30	4.40
Rotor Moment of Inertia	kg-m ²	3.01x10 ⁻⁶	5.20x10 ⁻⁶	9.20x10 ⁻⁶	1.30x10 ⁻⁵
	oz-in-s ²	0.0004	0.0007	0.0013	0.0018
Max. Radial Load	N	28	89	89	89
	lb	6	20	20	20
Max. Axial Load	N	28	89	89	89
	lb	6	20	20	20

Note:

- Performance is dependent upon heat sink configuration, system cooling conditions, and ambient temperature.
- Values shown @ 130°C rise above a 25°C ambient temperature, with motor mounted to a 250 mm x 250 mm x 6 mm aluminum heat sink.
- Peak torque assumes correct rms current; consult Aerotech.
- Torque constant and motor constant specified at stall.
- All performance and electrical specifications ±10%.
- Maximum winding temperature is 155°C.
- Ambient operating temperature range 0°C - 25°C; consult Aerotech for performance in elevated ambient temperatures.
- De-rate continuous torque and continuous current by 10% when using an encoder.
- All Aerotech amplifiers are rated A_{pk}; use torque constant in N-m/A_{pk} when sizing.

BM Series DIMENSIONS

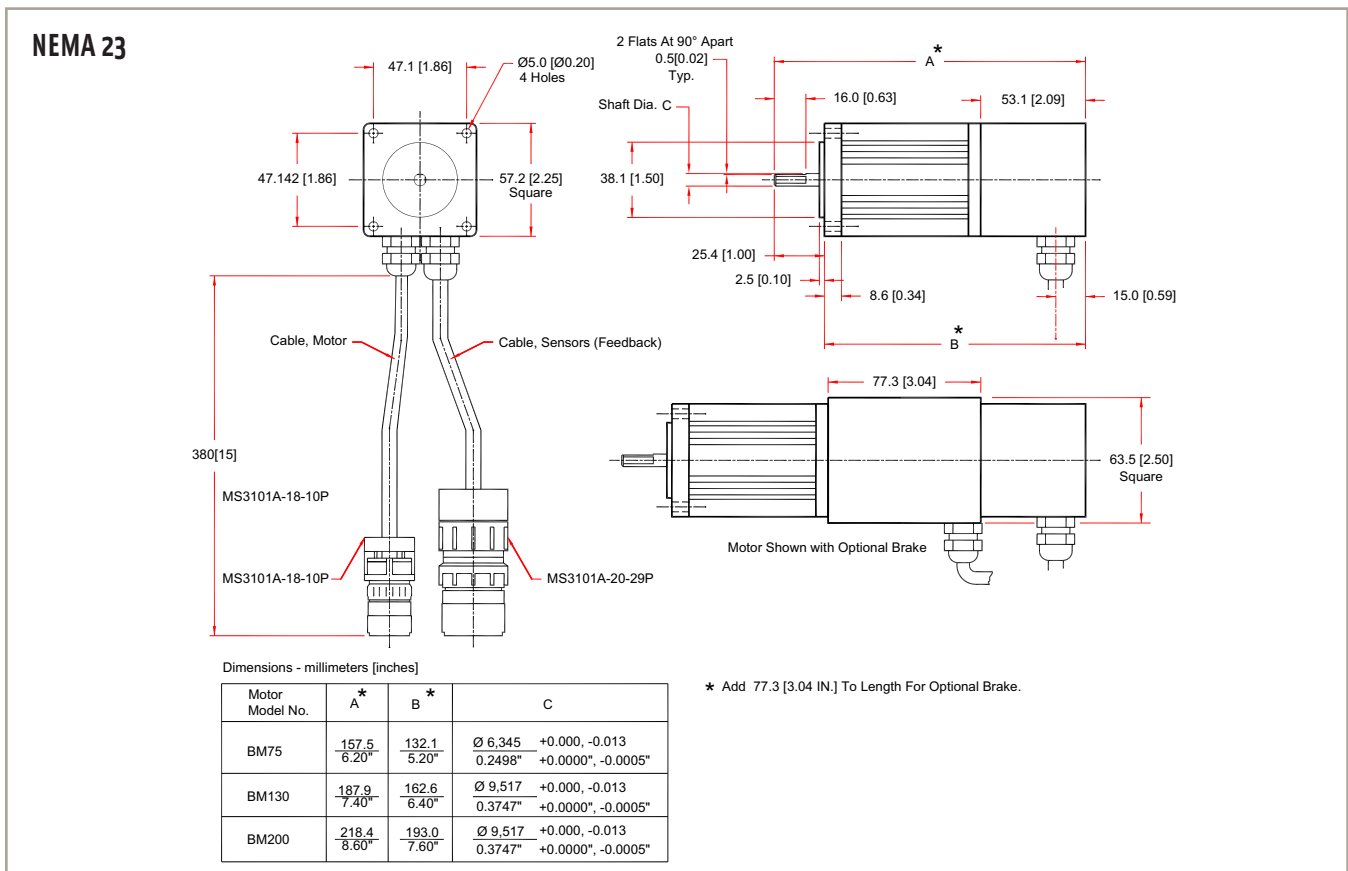
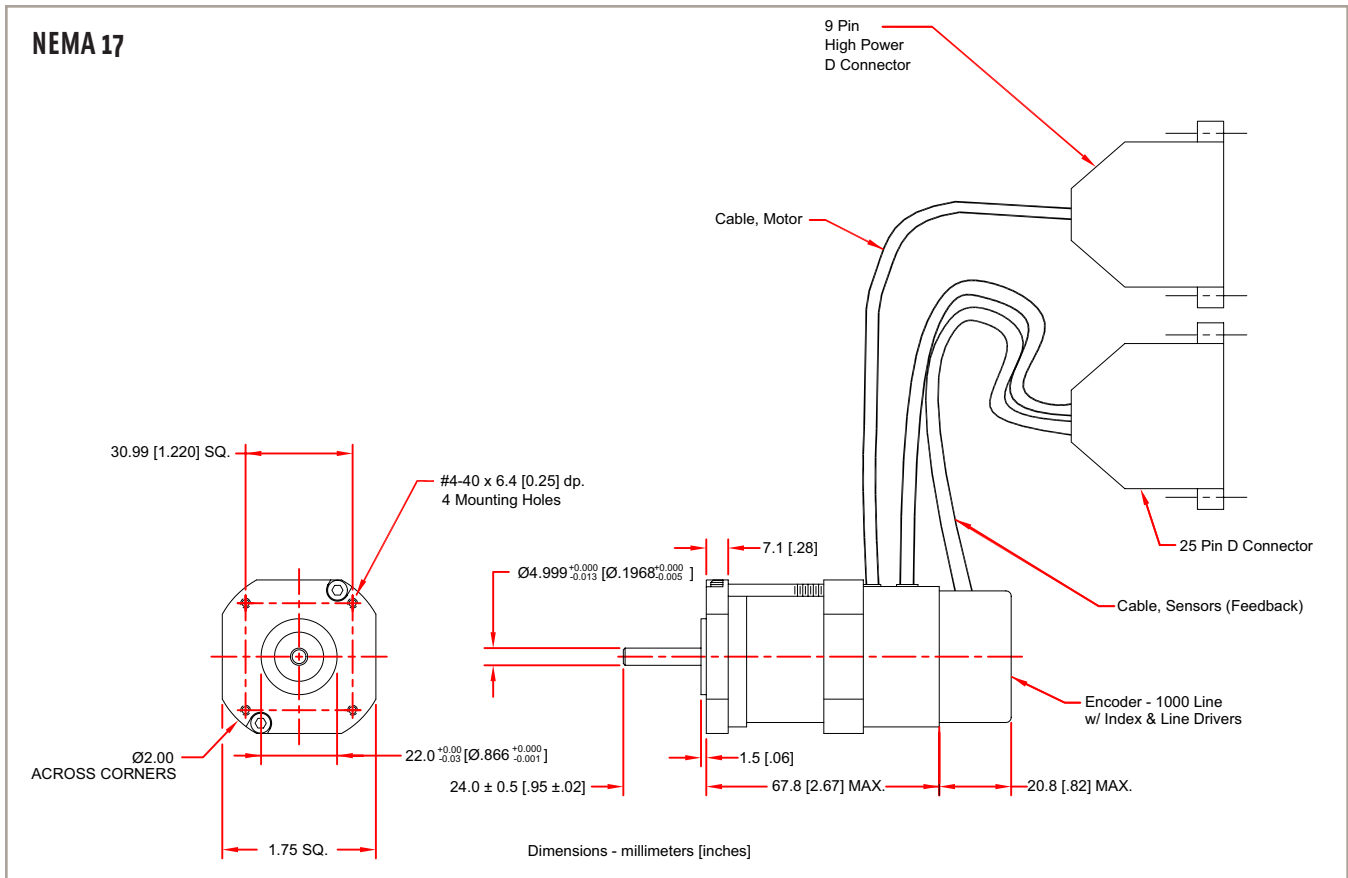

BM Series SPECIFICATIONS

Model		BM250	BM500
Performance Specifications^(1,5)			
Stall Torque, Continuous ^(2,8)	N-m	2.0	3.6
	oz-in	285	506
Peak Torque ⁽³⁾	N-m	5.0	8.9
	oz-in	712	1264
Rated Speed	rpm	4,000	4,000
Rated Power Output, Continuous	watts	843	1496
Electrical Specifications⁽⁵⁾			
BEMF Constant (line to line, max)	Volts _{pk} /krpm	23.2	24.7
Continuous Current, Stall ^(2,8)	Amp _{pk}	10.5	17.5
	Amp _{rms}	7.4	12.4
Peak Current, Stall ⁽³⁾	Amp _{pk}	26.3	43.8
	Amp _{rms}	18.6	30.9
Torque Constant ^(4,9)	N-m /Amp _{pk}	0.19	0.20
	oz-in /Amp _{pk}	27.1	28.9
	N-m /Amp _{rms}	0.27	0.29
	oz-in /Amp _{rms}	38.4	40.9
Motor Constant ^(2,4)	N-m/√W	0.171	0.270
	oz-in/√W	24.24	38.28
Resistance, 25°C (line to line)	ohms	1.1	0.5
Inductance (line to line)	mH	1.30	2.80
Maximum Bus Voltage	VDC	340	340
Thermal Resistance	C/W	0.94	0.74
Number of Poles	P	8	8
Mechanical Specifications			
Motor Weight	kg	3.6	5.0
	lb	7.92	11.00
Rotor Moment of Inertia	kg-m ²	7.85x10 ⁻⁵	1.39x10 ⁻⁴
	oz-in-s ²	0.0111	0.0197
Max. Radial Load	N	178	178
	lb	40	40
Max. Axial Load	N	89	89
	lb	20	20

Note:

- Performance is dependent upon heat sink configuration, system cooling conditions, and ambient temperature.
- Values shown @ 130°C rise above a 25°C ambient temperature, with motor mounted to a 250 mm x 250 mm x 6 mm aluminum heat sink.
- Peak torque assumes correct rms current; consult Aerotech.
- Torque constant and motor constant specified at stall.
- All performance and electrical specifications ±10%.
- Maximum winding temperature is 155°C.
- Ambient operating temperature range 0°C - 25°C; consult Aerotech for performance in elevated ambient temperatures.
- De-rate continuous torque and continuous current by 10% when using an encoder.
- All Aerotech amplifiers are rated A_{pk}; use torque constant in N-m/A_{pk} when sizing.

BM Series DIMENSIONS

NEMA 34

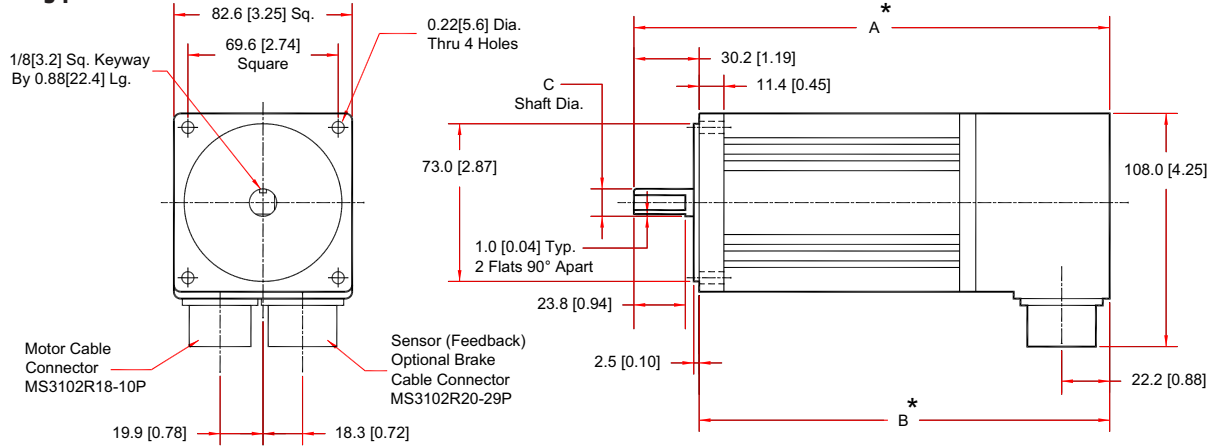

Dimensions - millimeters [inches]

Motor Model No.	A*	B*	C
BM250	$\frac{220.3}{8.67''}$	$\frac{190.0}{7.48''}$	$\frac{\text{Ø } 12.69}{0.4997''} \begin{matrix} +0.000, -0.013 \\ +0.0000'', -0.0005'' \end{matrix}$
BM500	$\frac{275.1}{10.83''}$	$\frac{244.9}{9.64''}$	$\frac{\text{Ø } 12.69}{0.4997''} \begin{matrix} +0.000, -0.013 \\ +0.0000'', -0.0005'' \end{matrix}$

* Add 55.6[2.19 IN.] To Length For Optional Brake.

BM Series SPECIFICATIONS

Model		BM800	BM1400
Performance Specifications^(1,5)			
Stall Torque, Continuous ^(2,8)	N-m	5.6	9.4
	oz-in	787	1336
Peak Torque ⁽³⁾	N-m	13.9	23.6
	oz-in	1966	3339
Rated Speed	rpm	3,000	3,000
Rated Power Output, Continuous	watts	1744	2962
Electrical Specifications⁽⁵⁾			
BEMF Constant (line to line, max)	Volts _{pk} /krpm	63.4	63.4
Continuous Current, Stall ^(2,8)	Amp _{pk}	10.6	18.0
	Amp _{rms}	7.5	12.7
Peak Current, Stall ⁽³⁾	Amp _{pk}	26.5	45.0
	Amp _{rms}	18.7	31.8
Torque Constant ^(4,9)	N-m /Amp _{pk}	0.52	0.52
	oz-in /Amp _{pk}	74.2	74.2
	N-m /Amp _{rms}	0.74	0.74
	oz-in /Amp _{rms}	104.9	104.9
Motor Constant ^(2,4)	N-m/√W	0.448	0.694
	oz-in/√W	63.44	98.28
Resistance, 25°C (line to line)	ohms	1.2	0.5
Inductance (line to line)	mH	3.80	1.70
Maximum Bus Voltage	VDC	340	340
Thermal Resistance	C/W	0.85	0.70
Number of Poles	P	8	8
Mechanical Specifications			
Motor Weight	kg	6.6	10.7
	lb	14.52	23.54
Rotor Moment of Inertia	kg-m ²	3.00x10 ⁻⁴	5.60x10 ⁻⁴
	oz-in-s ²	0.0425	0.0793
Max. Radial Load	N	222	222
	lb	50	50
Max. Axial Load	N	89	89
	lb	20	20

Note:

- Performance is dependent upon heat sink configuration, system cooling conditions, and ambient temperature.
- Values shown @ 130°C rise above a 25°C ambient temperature, with motor mounted to a 300 mm x 300 mm x 13 mm aluminum heat sink.
- Peak torque assumes correct rms current; consult Aerotech.
- Torque constant and motor constant specified at stall.
- All performance and electrical specifications ±10%.
- Maximum winding temperature is 155°C.
- Ambient operating temperature range 0°C - 25°C; consult Aerotech for performance in elevated ambient temperatures.
- De-rate continuous torque and continuous current by 10% when using an encoder.
- All Aerotech amplifiers are rated A_{pk}; use torque constant in N-m/A_{pk} when sizing.

BM Series DIMENSIONS

NEMA 42

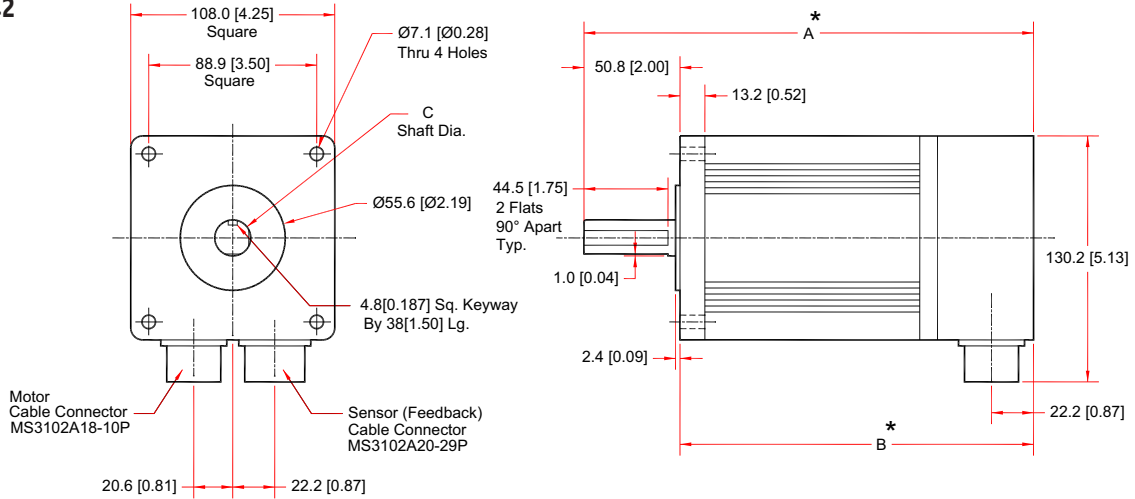

Dimensions - millimeters [inches]

Motor Model No.	A*	B*	C
BM800	238 9.37"	187 7.37"	Ø 19.04 +0.000, -0.013 0.7497" +0.0000", -0.0005"
BM1400	318 12.52"	267.2 10.52"	Ø 19.04 +0.000, -0.013 0.7497" +0.0000", -0.0005"

* Add 68.9 [2.71 IN.] To Length For Optional Brake.

BM Series SPECIFICATIONS

Motor Model	Units	BM2000	BM3400	BM4500
Performance Specifications^(1,5)				
Stall Torque, Continuous ⁽²⁾	N-m (lb-in)	14.7 (130)	23.7 (210)	31.6 (280)
Peak Torque ⁽³⁾	N-m (lb-in)	44.1 (390)	71.2 (630)	94.9 (840)
Rated Speed ⁽⁶⁾	rpm	2,400	2,400	2,400
Rated Power Output, Continuous	watts	3691	5962	7949
Electrical Specifications⁽⁵⁾				
BEMF Constant (line to line, max)	Volts _{pk} /krpm	99.0	99.0	113.1
Continuous Current, Stall ⁽²⁾	Amp _{pk}	16.5	26.7	31.1
	Amp _{rms}	11.7	18.9	22.0
Peak Current, Stall ⁽³⁾	Amp _{pk}	49.7	80.3	93.5
	Amp _{rms}	35.1	56.7	66.1
Torque Constant ^(4,8)	N-m/Amp _{pk}	0.89	0.89	1.01
	lb-in/Amp _{pk}	7.9	7.9	9.0
	N-m/Amp _{rms}	1.25	1.25	1.43
	lb-in/Amp _{rms}	11.1	11.1	12.7
Motor Constant ^(2,4)	N-m/ \sqrt{W}	1.13	1.86	2.31
	oz-in/ \sqrt{W}	10.0	16.5	20.5
Resistance, 25°C, line-line	ohms	0.54	0.20	0.17
Inductance (line-line)	mH	3.50	1.60	1.50
Maximum Bus Voltage	VDC	340	340	340
Thermal Resistance	C/W	0.78	0.80	0.69
Number of Poles	P	6	6	6
Mechanical Specifications				
Motor Weight	kg (lb)	15 (33.0)	23 (49.9)	30 (66.9)
Rotor Moment of Inertia	kg-m ²	1.25x10 ⁻³	2.23x10 ⁻³	3.24x10 ⁻³
	lb-in-s ²	0.0111	0.0197	0.0287
Max Radial Load	N (lb)	668 (150)	668 (150)	668 (150)
Max Axial Load	N (lb)	223 (50)	223 (50)	223 (50)

Note:

- Performance is dependent upon heat sink configuration, system cooling conditions, and ambient temperature.
- Values shown @ 130°C rise above a 25°C ambient temperature, with motor mounted to a 305 mm x 305 mm x 12.7 mm aluminum heat sink.
- Peak torque assumes correct rms current; consult Aerotech.
- Torque constant and motor constant specified at stall.
- All performance and electrical specifications $\pm 10\%$.
- Maximum winding temperature is 155°C.
- Ambient operating temperature range 0°C - 25°C; consult Aerotech for performance in elevated ambient temperatures.
- All Aerotech amplifiers are rated Apk; use torque constant in N-m/Apk when sizing.

BM Series DIMENSIONS

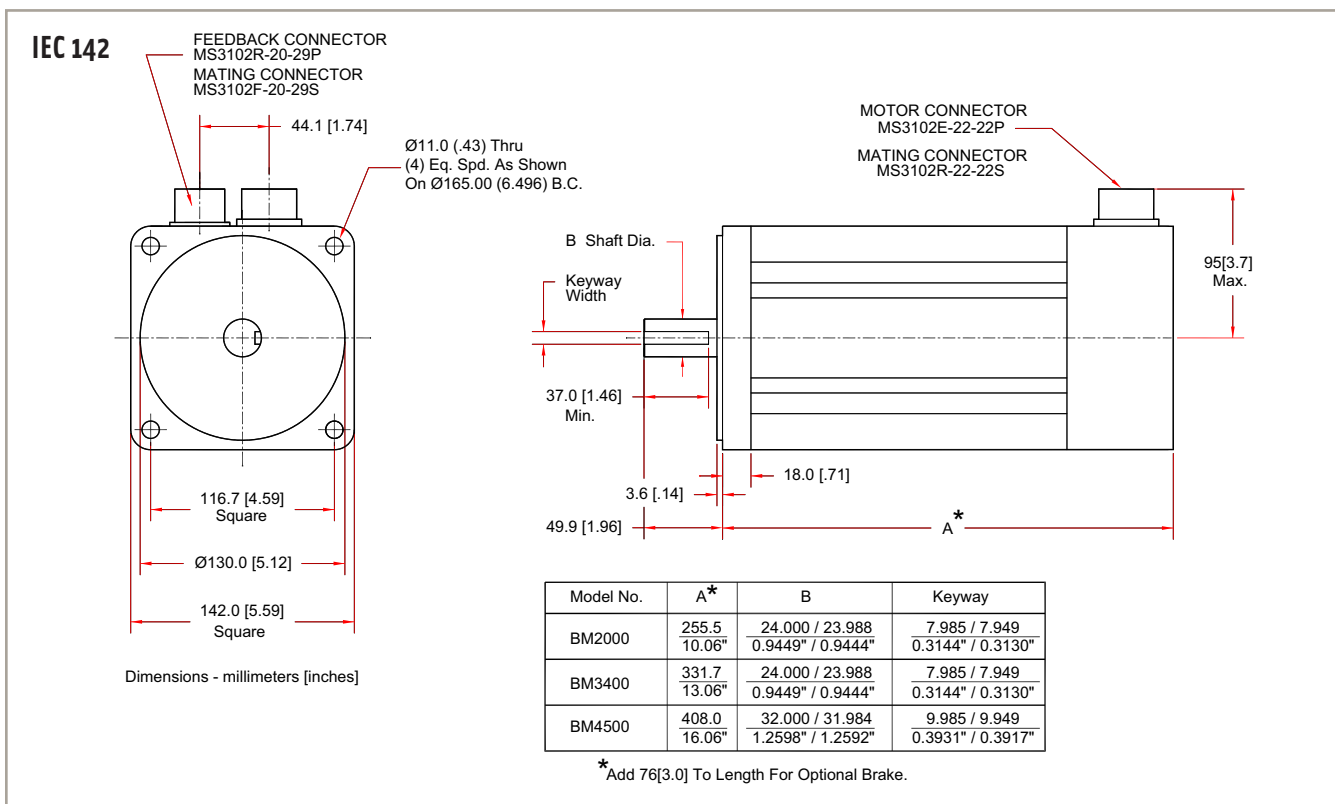

BM Series MOTOR PERFORMANCE

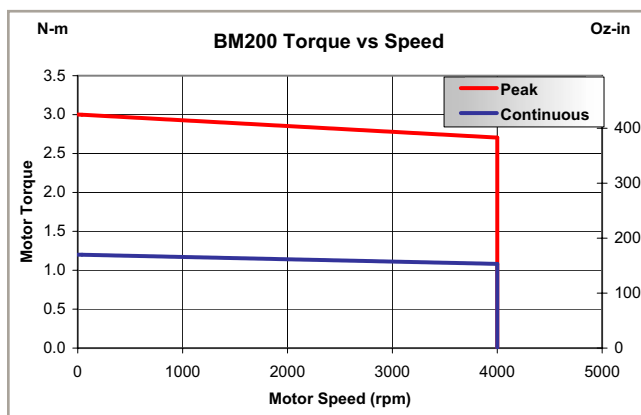
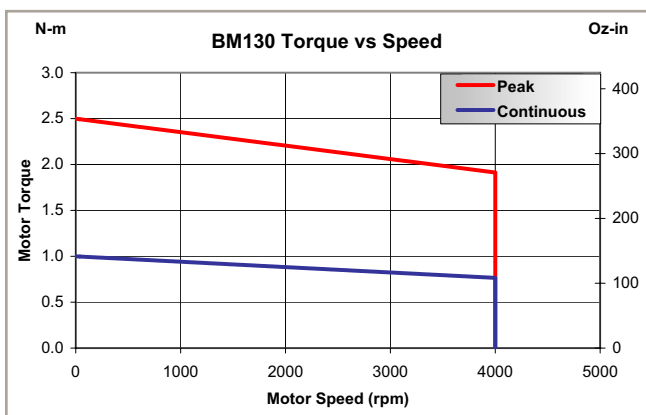
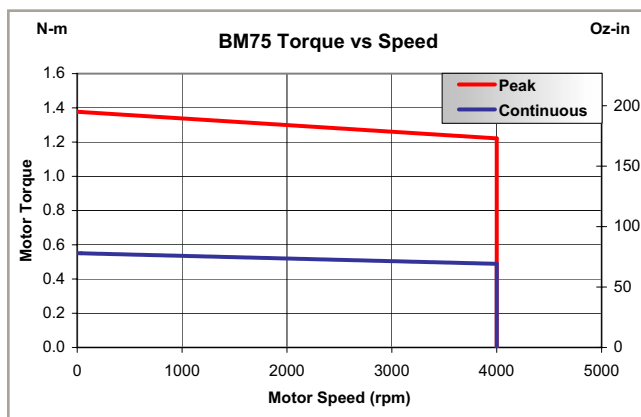
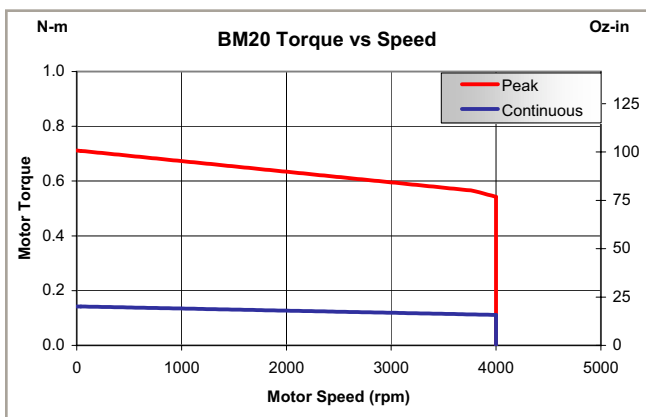

BM Series MOTOR PERFORMANCE

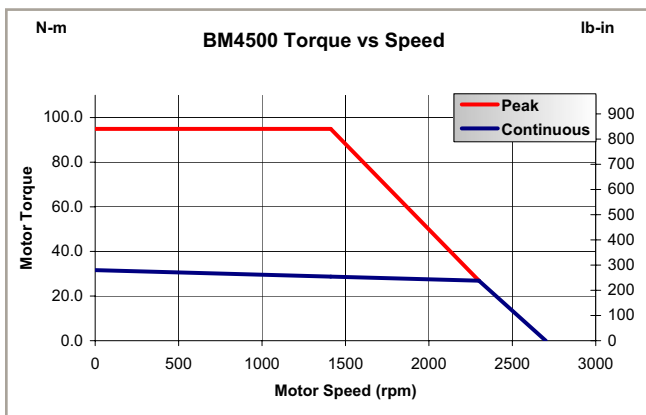
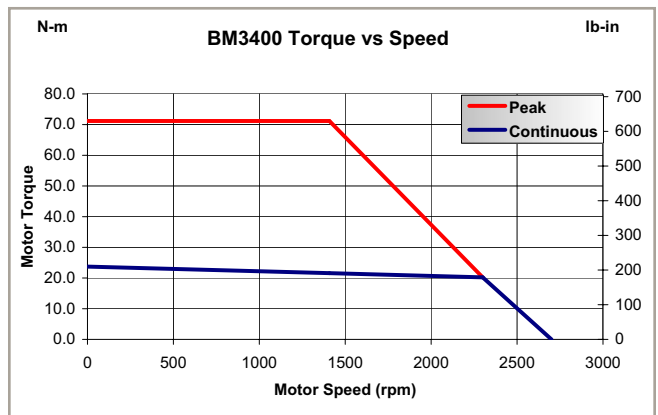
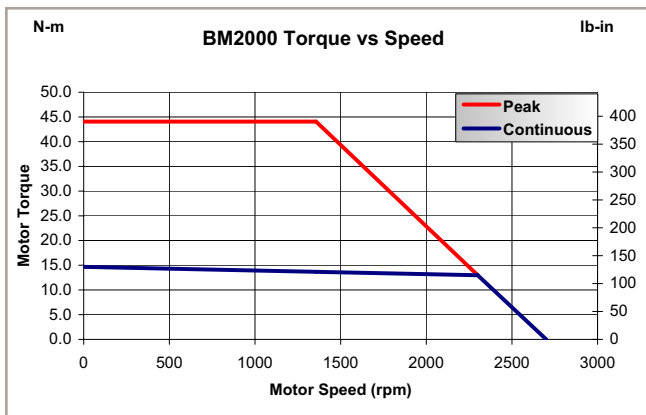
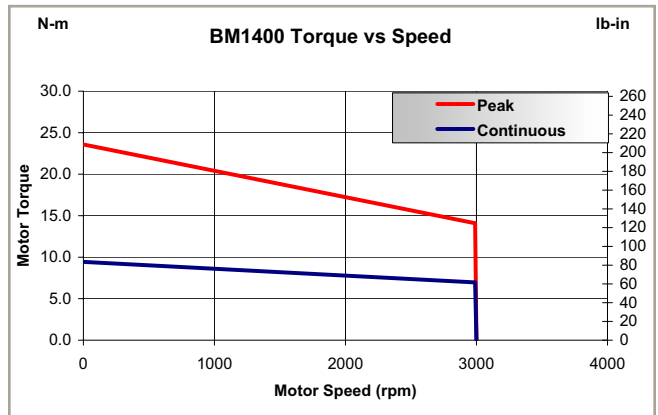
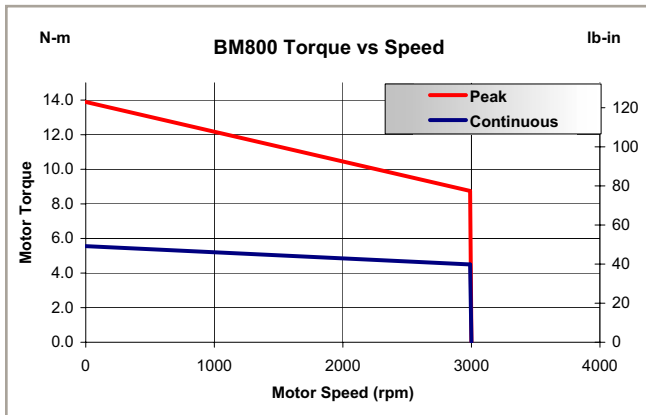
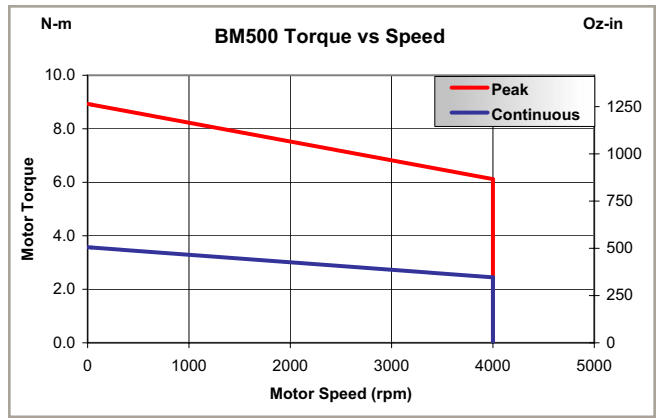
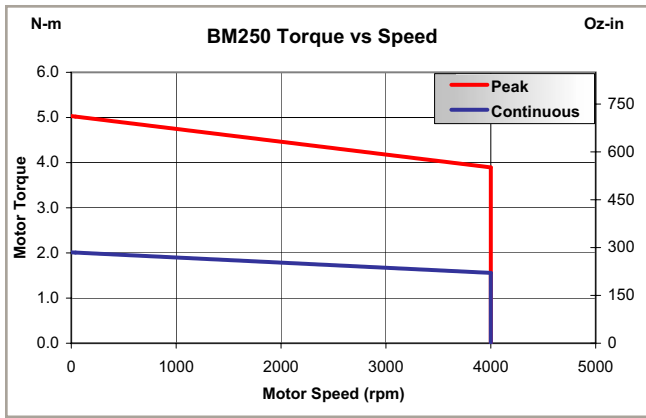

BM Series ORDERING INFORMATION

Ordering Example

BM	130	-MS	-E2000H	-BK1
Motor Series	Motor Torque (oz-in)	Connector Option	Encoder Resolution with Hall Tracks	Motor Options
	20, 75, 130, 200, 250, 500, 800, 1400, 2000, 3400, 4500	-MS -D25	E1000H, E2000H, E2500H, E5000H, RS	BK1, BK2, BK3, BK5, NS, VAC6

Standard motor/encoder = BM130E (MS connectors; E1000H encoder)

Brushless Rotary Servomotors

BM20	NEMA 17 brushless servomotor; 20.0 oz-in continuous torque
BM75	NEMA 23 brushless servomotor; 78.3 oz-in continuous torque
BM130	NEMA 23 brushless servomotor; 141.5 oz-in continuous torque
BM200	NEMA 23 brushless servomotor; 170.0 oz-in continuous torque
BM250	NEMA 34 brushless servomotor; 285 oz-in continuous torque
BM500	NEMA 34 brushless servomotor; 506 oz-in continuous torque
BM800	NEMA 42 brushless servomotor; 787 oz-in continuous torque
BM1400	NEMA 42 brushless servomotor; 1336 oz-in continuous torque
BM2000	IEC 142 brushless servomotor; 130 lb-in continuous torque
BM3400	IEC 142 brushless servomotor; 210 lb-in continuous torque
BM4500	IEC 142 brushless servomotor; 280 lb-in continuous torque

Connectors

-MS	MS connectors for feedback and motor power (standard)
-D25	D-shell for feedback and motor power (BM20 only)

Feedback Options

-E1000H	Encoder, A quad B with marker, 5 VDC, 1000 line, line-driver output (only option for BM20)
-E2000H	Encoder, A quad B with marker, 5 VDC, 2000 line, line-driver output
-E2500H	Encoder, A quad B with marker, 5 VDC, 2500 line, line-driver output (brake option not available on BM75, BM130)
-E5000H	Encoder, A quad B with marker, 5 VDC, 5000 line, line-driver output (brake option not available on BM75, BM130)
-RS	Single speed brushless resolver (replaces encoder)

Options (Brushless Rotary Motors)

-BK1	Brake; holding torque = 0.8 N-m (112 oz-in), 24 VDC, 0.3 A for BM75, BM130, and BM200
-BK2	Brake; holding torque = 1.7 N-m (240 oz-in), 24 VDC, 0.4 A for BM250, BM500
-BK3	Brake; holding torque = 5.6 N-m (800 oz-in), 24 VDC, 0.7 A for BM800, BM1400
-BK5	Brake; holding torque = 40.7 N-m (360 lb-in), 24 VDC, 0.7 A for BM2000, BM3400, BM4500
-NS	IP65 rated Nitrile front shaft seal (not available for BM75, BM130, BM200)
-VAC6	Vacuum prep for up to 10 ⁻⁶ torr

Example: Motor with 2000 line encoder and Nitrile shaft seal: BM250-MS-E2000H-NS

Accessories

MCM1-3	Connector, MS motor power mate (BM2000, BM3400, BM4500)
MCM-3	Connector, MS motor power mate (BM75, BM130, BM200, BM250, BM500, BM800, BM1400)
MCF-3	Connector, MS motor feedback mate for all BM motors